

High Level Order Picker

Rider Operation 1,000kg Capacity

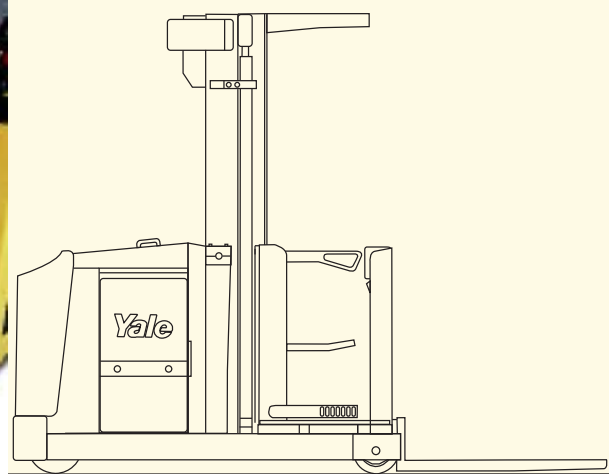

- Yale AC technology
- AC motors
- Canbus
- Fly-by-wire steering
- Enhanced comfort and performance
- Low maintenance features

Truck Dimensions

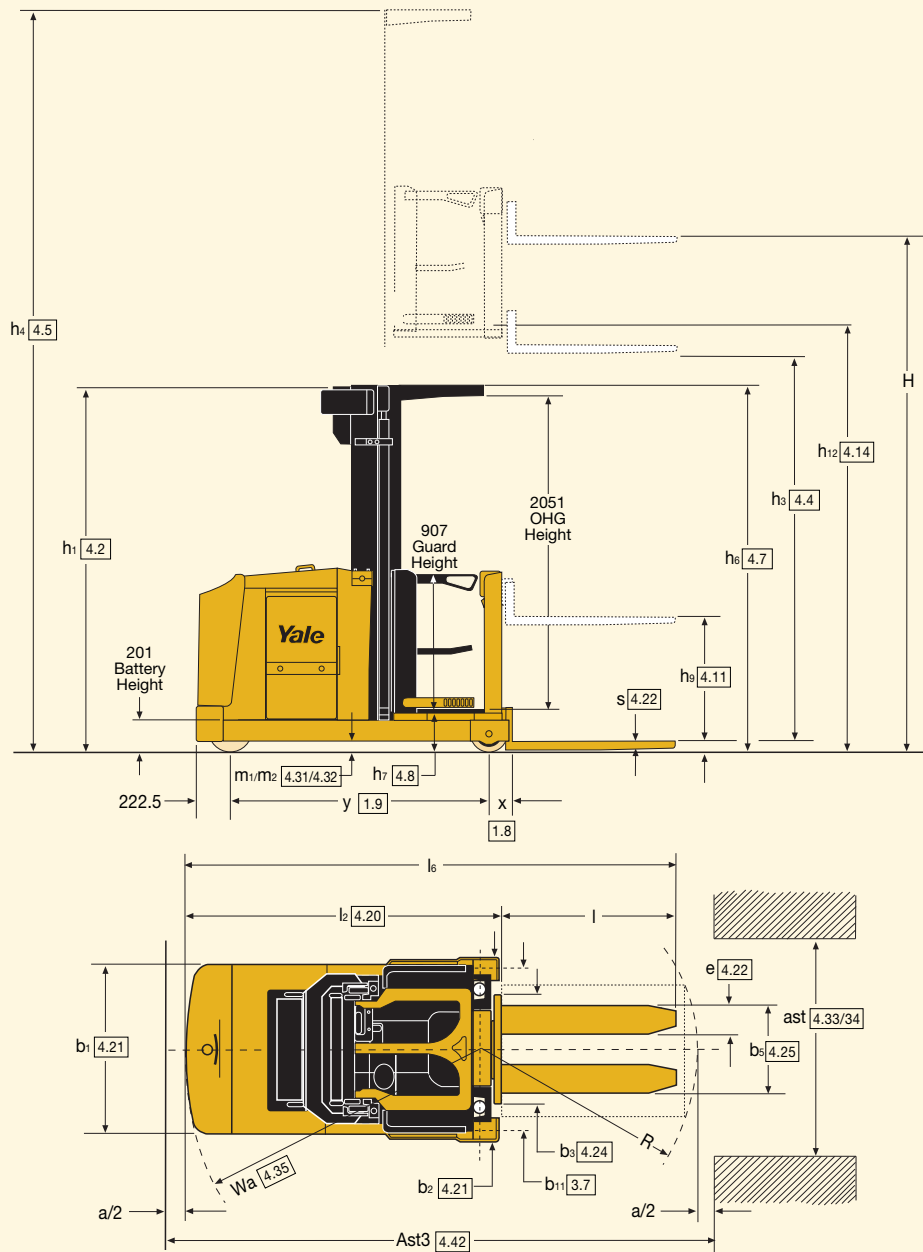

Mast details

Model	Mast type	b2	H(*)	h12	h9	h3	h1	h4
MO10	2 stage	1000	4230	3620	770	3370	2420	5740
		1000	4530	3920	770	3670	2570	6040
		1000	5130	4520	770	4270	2870	6640
		1000	5630	5020	770	4770	3120	7140
		1000	6130	5520	770	5270	3370	7640
MO10S	2 stage	1100 or 1200	4230	3620	770	3370	2420	5740
		1100 or 1200	4530	3920	770	3670	2570	6040
		1100 or 1200	5130	4520	770	4270	2870	6640
		1100 or 1200	5630	5020	770	4770	3120	7140
		1100 or 1200	6130	5520	770	5270	3370	7640
		1100 or 1200	6630	6020	770	5770	3620	8140
		1100 or 1200	7130	6520	770	6270	3870	8640
MO10S	3 stage	1100 or 1200	5705	5095	770	4845	2370	7215
		1100 or 1200	6005	5395	770	5145	2470	7515
		1100 or 1200	6605	5995	770	5745	2670	8115
		1100 or 1200	7205	6595	770	6345	2870	8715
		1200	7805	7195	770	6945	3070	9315
		1200	8405	7795	770	7545	3270	9915
		1200	9005	8395	770	8145	3470	10515

(*) Total forklift height when equipped with FEM forks - 50 mm.

VDI 2198 - General Specifications

		Yale	Yale	Yale		
Characteristics	1.1	Manufacturer	Yale	Yale	Yale	
	1.2	Model designation	MO10	MO10S	MO10S	
	1.3	Power: battery, diesel, LPG, electric mains	Battery	Battery	Battery	
	1.4	Operation; manual, pedestrian, stand, seat	Stand-on	Stand-on	Stand-on	
	1.5	Load capacity	Q (t)	1	1	1
	1.6	Load centre	c (mm)	600	600	600
	1.8	Load distance ⁽¹⁾	x (mm)	190	150	205
	1.9	Wheel base	y (mm)	1534,5	1574,5	1674,5
	Weights	2.1	Unloaded weight (included battery)	kg	2940	3070
2.2		Axle loading with load, front/rear	kg	1255 / 2685	1365 / 2705	1480 / 2740
2.3		Axle loading without load, front/rear	kg	1650 / 1290	1780 / 1290	1980 / 1315
Wheels and Tyres	3.1	Tyres: rubber, polyurethane, vulkollan, front/rear	Vulkollan / Vulkollan	Vulkollan / Vulkollan	Vulkollan / Vulkollan	
	3.2	Tyre size, front	ø 343 x 140	ø 343 x 140	ø 343 x 140	
	3.3	Tyre size, rear	ø 200 x 80	ø 200 x 80	ø 200 x 100	
	3.5	Wheels number front/rear (x = driven)	1 x / 2	1 x / 2	1 x / 2	
	3.6	Track width, front	b 10 (mm)	-	-	-
	3.7	Track width, rear	b 11 (mm)	877	977	1057
	Dimensions	4.2	height of mast, lowered (Cab)	h1 (mm)	See Table	See Table
4.3		Free lift	h2 (mm)	---	---	---
4.4		Lift height	h3 (mm)	See Table	See Table	See Table
4.5		height of mast, extended ⁽²⁾	h4 (mm)	See Table	See Table	See Table
4.7		Overhead guard height ⁽²⁾	h6 (mm)	2370	2370	2370
4.8		Platform height	h7 (mm)	250	250	250
4.11		Auxiliary Lift	h9 (mm)	770	770	770
4.14		Height platform raised	h12 (mm)	See Table	See Table	See Table
4.15		Lowered Height ⁽³⁾	h13 (mm)	90	90	90
4.19		Overall length ⁽¹⁾	l1 (mm)	3087	3087	3242
4.20		Length to face of forks ⁽¹⁾	l2 (mm)	1947	1947	2102
4.21		Overall width ⁽⁴⁾	b1/b2 (mm)	1000/1000	1100/1100	1100/1200
4.22		Fork dimensions ⁽⁵⁾	s/e/l (mm)	60 / 180 / 1140	60 / 180 / 1140	60 / 180 / 1140
4.23		Fork carriage DIN 15173, Class/form A, B		-	-	-
4.24		Fork carriage width ⁽⁶⁾	b3 (mm)	700 / 780 / 860	700 / 780 / 860	700 / 780 / 860
4.25		Outside fork width min./max ⁽⁷⁾	b5 (mm)	520 / 560 / 680	520 / 560 / 680	520 / 560 / 680
4.27		Width over guide rollers	b6 (mm)	-	-	-
4.31		Ground clearance under mast, with load	m1 (mm)	60	60	60
4.32		Ground clearance centre of wheelbase	m2 (mm)	30	30	30
4.33		Aisle width with pallet 1000 x 1200 crossways VDI 2198	Ast (mm)	1400	1400	1400
4.34	Aisle width with pallet 800 x 1200 lengthwise VDI 2198 ⁽⁸⁾	Ast (mm)	1200	1300	1400	
4.35	Turning radius	Wa (mm)	1768	1809	1905	
4.42	Transfer aisle width with pallet 800 x 1200 long (Wa + R + a)	Ast3 (mm)	3414	3417	3566	
Performance	5.1	Travel speed with/without load	km/h	8,8 / 9	8,8 / 9	8,8 / 9
	5.2	Lift speed with/without load (Cab)	m/s	0,36 / 0,42	0,37 / 0,43	0,37 / 0,43
	5.2	Lift speed with/without load (SL)	m/s	0,22 / 0,24	0,22 / 0,24	0,22 / 0,24
	5.3	Lowering speed with/without load (Cab)	m/s	0,37 / 0,37	0,38 / 0,38	0,38 / 0,38
	5.3	Lowering speed with/without load (SL)	m/s	0,20 / 0,20	0,20 / 0,20	0,20 / 0,20
	5.7	Gradeability with/without load ⁽⁹⁾	%	10 / 15	10 / 15	10 / 15
	5.8	Max. gradeability with/without load ⁽⁹⁾	%	10 / 15	10 / 15	10 / 15
	5.9	Acceleration time (10 mt) with/without load ⁽¹⁰⁾	s	5,0 / 6,0	5,0 / 6,0	5,0 / 6,0
	5.10	Service Brake		el.magnetic	el.magnetic	el.magnetic
	Power Unit	6.1	Drive motor, S2 60 minute rating	kW	6.4	6.4
6.2		Lift motor, S3 15% rating	kW	12	12	12
-		Steering motor	kW	0.4	0.4	0.4
6.3		Battery according to DIN 43531/35/36 A,B,C, no		DIN 43531 A	DIN 43531 B	DIN 43531 B
6.4		Battery voltage/capacity at 5 hours rate	V/Ah	48 / 280 - 310	48 / 420 - 465	48 / 560 - 620
6.5		Battery weight (+/- 5%)	kg	680-700-720	732-750-765	948-965-995
Misc.	6.6	Consumptions according to VDI cycle	kWh/h	/	/	/
	8.1	Drive control		AC ~ Mosfet	AC ~ Mosfet	AC ~ Mosfet
8.4	Average noise level at operator's ear	dB (A)	< 70	< 70	<70	

(1) SL model: with Fem carriage and forks 100x35 + 25mm.

(2) Models with Over Head Guard: with lift interrupt mounted on OHG, h6 + 105mm

(2) With flashing light h6 +120mm if fitted on Overhead Guard

(3) With Fem carriage and forks 80 x 30, h13 = 35mm.

(4) With Fem carriage and forks 100 x 35, h13 = 40mm.

(4) Model with Fem carriage, b2 = 800mm

(5) Also available with Fem carriage and fork size 100 x 35 with 1000Kg @ 600mm

(6) Model with Fem carriage, b3 = 800mm

(7) Model with Fem carriage and forks 100 x 35, b5 = 773mm.

(8) All models: AST with A/2 = 100mm.

(9) Values determined by wheel friction, if climbing ramps frequently (within 1h), consult your salesman.

(10) Acceleration 3 performance preset levels available selectable by the operator - soft, medium and hard.

Models: MO10, MO10S

Operator's compartment

The large operator cab allows the operator to find the most comfortable driving position.

The platform is cushioned to absorb vibrations and incorporates an operator presence switch over the entire surface area, which avoids the frustrating search for the traditional enabling switch. The cabin bulk head is angled and padded to facilitate access to the load support. The interlocked side gates must be lowered to enable traction above 1200mm cab lift height. The side gates are spring assisted and the integral toe board lifts up with the side arms to maintain a low step height for on/off access. The low step height is a further aid to driver comfort and productivity. An abseil device is provided with the truck.

Storage facilities are located under the control console.

Controls

The controls are- nested between the mast uprights, maximising the walk-through area of the platform for easy pick-face access either side of the aisle. The graphic display is readable under all light conditions and contains a wealth of truck status information including:

- steer wheel position indicator
- cabin platform height indicator
- traction speed
- lift height
- fault display
- battery discharge indicator
- load weight

Additional functions easily accessible are:-

- sensor tests
- PIN code insertion
- adjustable height stop

The control console is mounted on the drive side of the truck. The butterfly switch controls, travel speed and forward /reverse direction. Whilst the mini-lever controls the main lift/lower function for efficiency. The red mushroom shaped button can be activated to stop the truck immediately in case of emergency. The left mini-lever also acts as an emergency stop actuator.

Steering

The electric steering system is "fly-by-wire" technology and incorporates a high efficiency AC motor. An ergonomically designed steering wheel is adjustable for enhanced steering feedback.

The self-centring steering mechanism works automatically when the truck is turned on, via a push button on the control panel or when the creep speed advance mode is activated. On entering a guided aisle the steer wheel is automatically centred and steering is disengaged.

Creep Speed Advance

The three "pedestrian mode" buttons function allows the operator to advance the truck in creep speed, and lift or lower the forks while on the ground.

Mast

The "Delta" profile mast section provides torsional rigidity and minimises deflection. The panorama design provides excellent visibility of the working environment. Slack chain detection devices mounted on the mast prevent further lowering if an obstacle is encountered. Lowering speed is automatically reduced as the cab nears the floor. Two stage mast options are offered on all models with a three stage mast option available on the MO10S. A strobe light is mounted on the chassis behind the mast.

Supplementary lift

The supplementary carriage/forks are mounted on a cab bulk head and provide auxiliary lift. The materials handling interface and/or load can be raised or lowered to maintain a constant comfortable working height, reducing bending and stretching for the operator. The auxiliary lift/lower control requires two-handed operation

Traction – steering unit

A powerful 6.4kW AC traction motor with instant response to forward and reverse traction inputs, provides considerable torque, delivers fast acceleration and travel speeds matched to the model specification, with no difference in unladen and laden performance. The fixed motor and vertically mounted drive unit eliminate flexing stresses to the power cables to ensure reduced down time.

An AC MOSFET traction controller provides energy efficient operation. The controller features automatic release braking and regenerative braking on release of the butterfly. The performance parameters can be adjusted using an ETACS or external handset. Self diagnostics and thermal protection are features of the controller. The maintenance free motor (inspection intervals every 1000 operating hours) provides low cost long operational life.

The speed of operation are under the full control of the MOSFET system and are relative to the cab height and load weight. This delivers the maximum truck performance in all working conditions.

Hydraulic system

The 12kW AC pump motor guarantees consistent performance matched to the model specification. The AC MOSFET control provides proportional handling for lifting through control of the motor as well as proportional control on lowering movements of the cab and supplementary lift. The pump motor regenerative action provides efficient

energy management, smooth starting and stopping.

Hose break valves prevent lowering in the event of a line break and a manual lowering valve allows emergency cab lowering to the ground.

Brakes

An electromagnetic brake is mounted on the drive motor. It is spring applied and electrically released. The electromagnetic brake is opened and closed by a platform sensor and is used as a parking brake. Electric braking (plugging) is available for normal service braking. Regenerative braking is automatically applied on release of the butterfly speed control.

Battery

The trucks are 48V with the following battery options:

MO10 - 250 to 320Ah

MO10S - 375 to 640Ah

A flip up cover provides easy access for battery servicing and checking. The battery is mounted on rollers to facilitate left side extraction with a roller bed trolley available as an option.

Guidance options

Trucks may be free ranging or fitted with guidance options. Guided trucks can increase productivity as maximum speed can be maintained to higher heights inside the working aisle as the driver can simultaneously travel and lift or lower without having to focus on steering. Guidance options include wire-guidance package or rollers for rail guidance. The on-board wire-guidance package includes sensors mounted fore and aft as well as a truck logic module linked to the steering system. The standard operating frequency is 6.25 kHz.

Options

A full complement of options is, available including:

- Cold store applications
- Different cabin widths
- Height/speed interlocks
- Lift interrupt on the overhead guard
- End of aisle controls (slow-down and stop)
- Guidance options
- Varied size rollers
- Wire - guidance varied frequency
- Frequency generator
- Frequency options
- Work lights
- Fixed forks
- Fan
- Pick list holder
- Pin code access



NACCO Materials Handling Limited
trading as **Yale Europe Materials Handling**
Flagship House, Reading Road North,
Fleet, Hampshire GU51 4WD, United Kingdom.
Tel: + 44 (0) 1252 770700 Fax: + 44 (0) 1252 770784
www.yale-europe.com

Country of Registration: England. Company Registration Number: 02636775



Safety. This truck conforms to the current EU requirements. Specification is subject to change without notice

Publication part no. 258985571 Rev.02
Printed in The United Kingdom (030810HG) EN

Yale is a registered trade mark.
© Yale Europe Materials Handling 2008. All rights reserved.

Truck shown with optional equipment