

MR Series

Reach Trucks with AC Technology

1,400kg, 1,600kg, 2,000kg and 2,500kg

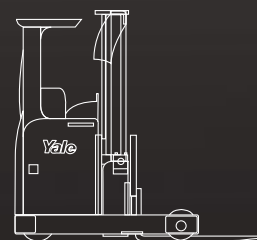

- AC technology on traction, hoist and steering motors
- PalmTech joystick control
- 360° steering
- Tilting fork carriage with integral sideshift
- Progressive fly by wire steering

Yale 
People. Products. Productivity.

Truck Dimensions

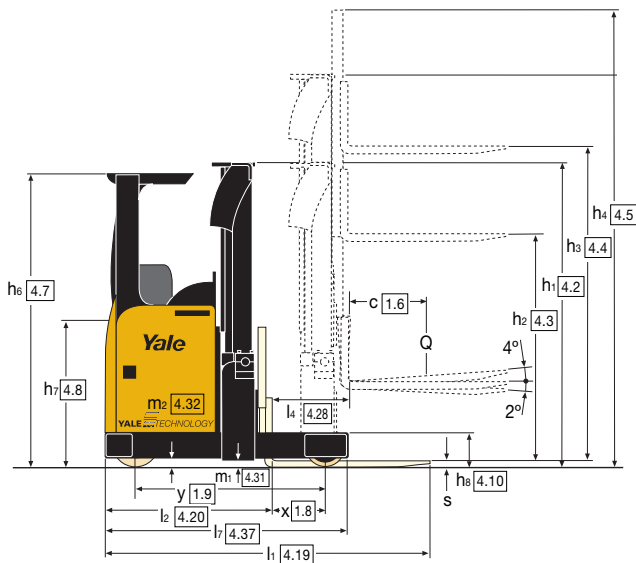

$$Ast = Wa + R + a$$

$$R = \sqrt{(l_6 - x)^2 + \left(\frac{b_{12}}{2}\right)^2}$$

$$a = 200\text{mm}$$

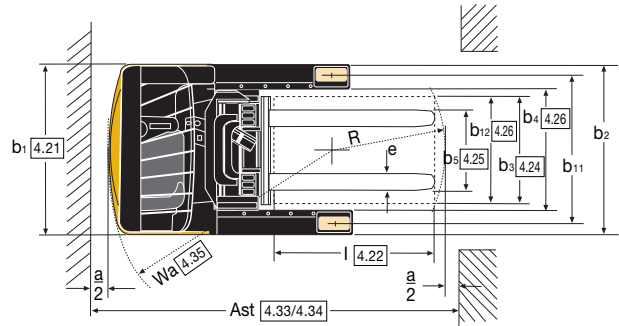

Mast details - 3 stage full free lift

Model	Lift (h ₃) mm VDI 14.4	Free lift (h ₂) mm VDI 14.3	Height of mast lowered (h ₁) mm VDI 14.2	Height of mast extended (h ₄) mm VDI 14.5 ^(*)	Fork carriage tilt forwards/backwards
MR14, MR16, MR16N	4626	1555	2125	5676	2° / 4°
	5076	1705	2275	6126	2° / 4°
	5526	1855	2425	6576	2° / 4°
	6426	2155	2725	7476	2° / 4°
	6876	2305	2875	7926	2° / 4°
MR14H, MR16N, MR16H	7026	2455	3025	8076	2° / 4°
	7476	2605	3175	8526	2° / 4°
	8076	2805	3375	9126	2° / 4°
	8526	2955	3525	9576	2° / 4°
MR14H, MR16N	8726	3155	3725	9776	2° / 4°
MR16H	9026	3255	3825	10076	2° / 4°
	9176	3305	3875	10526	2° / 4°
MR20	4626	1555	2125	5676	2° / 4°
	5076	1705	2275	6126	2° / 4°
	5526	1855	2425	6576	2° / 4°
	6426	2155	2725	7476	2° / 4°
MR20H MR25, MR20W	4526	1555	2125	5576	2° / 4°
	4976	1705	2275	6026	2° / 4°
	5426	1855	2425	6476	2° / 4°
	6326	2155	2725	7376	2° / 4°
	6776	2305	2875	7826	2° / 4°
	7026	2455	3025	8076	2° / 4°
	7476	2605	3175	8526	2° / 4°
	8076	2805	3375	9126	2° / 4°
MR16H MR20H, MR25	8526	2955	3525	9576	2° / 4°
	9026	3255	3825	10076	2° / 4°
	9476	3405	3975	10526	2° / 4°
	10076	3705	4275	11126	2° / 4°
	10526	3855	4425	11576	2° / 4°
MR16HD 700Ah Battery MR20HD 700Ah Battery	11426	4155	4725	12476	2° / 4°
	7502	2605	3165	8502	2° / 4°
	8102	2805	3365	9102	2° / 4°
	8552	2955	3515	9552	2° / 4°
	9028	3255	3815	10028	2° / 4°
	9478	3405	3965	10478	2° / 4°
	10078	3705	4265	11078	2° / 4°
	10528	3855	4415	11528	2° / 4°
	10978	4005	4565	11978	2° / 4°
	11428	4155	4715	12428	2° / 4°
	9452	3255	3815	10452	2° / 4°
	9902	3405	3965	10902	2° / 4°
	10378	3705	4265	11378	2° / 4°
10828	3855	4415	11828	2° / 4°	
11278	4005	4565	12278	2° / 4°	
MR20HD 840Ah Battery	10802	3705	4265	11802	2° / 4°
	11252	3855	4415	12252	2° / 4°
	11702	4005	4565	12702	2° / 4°
	11728	4155	4715	12728	2° / 4°
	12152	4155	4715	13152	2° / 4°

^(*) Value determined with load backrest.

VDI 2198 - General Specifications

		Yale			Yale			Yale			Yale				
Characteristics	1.1	Manufacturer	Yale			Yale			Yale			Yale			
	1.2	Model designation	MR14			MR14H			MR16			MR16H			
	1.3	Power: Battery, Diesel, LPG, Electric mains	Battery			Battery			Battery			Battery			
	1.4	Operation: Manual, pedestrian, stand-on, seated	Seated			Seated			Seated			Seated			
	1.5	Load capacity	Q (t)	1.4			1.4			1.6			1.6		
	1.6	Load centre	c (mm)	600			600			600			600		
	1.8	Load distance	x (mm)	465	393	321	480	408	336	515	443	371	-	443	371
	1.9	Wheelbase	y (mm)	1435			1450			1485			1485		
	Weights	2.1	Unloaded weight	kg	2980 ⁽⁵⁾			3440 ⁽⁵⁾			3000 ⁽⁵⁾			3680 ⁽⁵⁾	
2.3		Axle loading without load, front/rear ⁽⁶⁾	kg	2010	970 ⁽⁵⁾		2220	1220 ⁽⁵⁾		2010	990 ⁽⁵⁾		2340	1340 ⁽⁵⁾	
2.4		Axle loading mast extended load, front/rear ⁽⁶⁾	kg	850	3530 ⁽⁵⁾		770	4070 ⁽⁵⁾		680	3920 ⁽⁵⁾		800	4480 ⁽⁵⁾	
2.5		Axle loading mast retracted with load, front/rear ⁽⁶⁾	kg	1860	2520 ⁽⁵⁾		1970	2870 ⁽⁵⁾		1860	2740 ⁽⁵⁾		2140	3140 ⁽⁵⁾	
Wheels and Tyres		3.1	Tyres: rubber, polyurethane, front/rear		Vulkollan	Vulkollan		Vulkollan	Vulkollan		Vulkollan	Vulkollan		Vulkollan	Vulkollan
	3.2	Tyre size - front		Ø 305 x 140			Ø 305 x 140			Ø 305 x 140			Ø 342 x 140		
	3.3	Tyre size - rear		Ø 250 x 100			Ø 285 x 100			Ø 350 x 100			Ø 350 x 100		
	3.5	Wheels - number front/rear (x = driven)		1 x /2			1 x /2			1 x /2			1 x /2		
	3.6	Track width - front	b10 (mm)	-			-			-			-		
	3.7	Track width - rear	b11 (mm)	1126			1126			1136			1136		
	Dimensions	4.1	Tilting fork carriage, forwards/backwards tilt a / β	Degrees	2 / 4			2 / 4			2 / 4			2 / 4	
4.2		Height of mast, lowered	h1 (mm)	see table			see table			see table			see table		
4.3		Free lift	h2 (mm)	see table			see table			see table			see table		
4.4		Lift height	h3 (mm)	see table			see table			see table			see table		
4.5		Height of mast extended ⁽⁶⁾	h4 ⁽⁶⁾ (mm)	see table			see table			see table			see table		
4.7		Overhead guard height (cabin) ⁽¹⁾	h6 (mm)	2190 ⁽⁸⁾			2190 ⁽⁸⁾			2190 ⁽⁸⁾			2190 ⁽⁸⁾		
4.8		Seat height ⁽²⁾	h7 (mm)	1075 ⁽²⁾			1075 ⁽²⁾			1075 ⁽²⁾			1075 ⁽²⁾		
4.10		Height of load arms ⁽⁹⁾	h8 (mm)	260			285 ⁽¹⁾			350 ⁽¹⁾			350 ⁽¹⁾		
4.19		Overall length ⁽¹⁾	l1 (mm)	2400	2472	2544	2400	2472	2544	2400	2472	2544	-	2472	2544
4.20		Length to face of forks	l2 (mm)	1200	1272	1344	1200	1272	1344	1200	1272	1344	-	1272	1344
4.21		Overall width	b1/b2 (mm)	1270			1270			1270			1270		
4.22		Fork dimensions	s/e/l (mm)	35	100	1200	35	100	1200	35	100	1200	35	120	1200
4.23		Fork carriage to DIN 15173, Class/form A, B		2A			2A			2A			2A		
4.24		Fork carriage width	b3 (mm)	800			800			800			800		
4.25		Outside fork width min./max.	b5 (mm)	240	672		240	672		270	702		270	702	
4.26		Width between load arms	b4 (mm)	900			900			900			900		
4.28		Reach	l4 (mm)	635	563	491	665	593	521	735	663	591	-	663	591
4.31		Ground clearance beneath mast, laden ⁽⁷⁾	m1 (mm)	75			75			75			75		
4.32		Ground clearance, centre of wheelbase ⁽⁷⁾	m2 (mm)	75			75			75			75		
4.33		Aisle width for pallet 1000 x 1200 crossways VDI 2198 (Wa + R + a)	Ast (mm)	2692	2741	2794	2696	2745	2797	2708	2755	2805	-	2755	2805
		Aisle width with pallet 1000 x 1200 crossways BITA GN9 (D + a)	Ast (mm)	2627	2690	2754	2627	2690	2754	2627	2690	2754	-	2690	2754
	4.34	Aisle width with pallet 800 x 1200 lengthwise VDI 2198 (Wa + R + a)	Ast (mm)	2725	2789	2854	2726	2789	2854	2729	2792	2856	-	2792	2856
		Aisle width with pallet 800 x 1200 lengthwise VDI 3597 (Wa + l6 -x + a)	Ast (mm)	2623	2695	2767	2622	2694	2766	2621	2693	2766	-	2693	2765
	4.35	Turning radius	Wa (mm)	1688			1702			1736			1736		
	4.37	Length over load arms	l7 (mm)	1815			1845			1915			1915		
Performances	5.1	Travel speed, laden/unladen ^{(4) (6)}	km/h	10	12		10	12		10	12		10	12	
	5.2	Lift speed, laden/unladen ^{(4) (6)}	m/s	0.36	0.52		0.36	0.52		0.36	0.52		0.36	0.52	
	5.3	Lowering speed, laden/unladen ^{(4) (6)}	m/s	0.53	0.51		0.53	0.51		0.53	0.51		0.53	0.51	
	5.4	Reach speed, laden/unladen ^{(4) (6)}	m/s	0.15	0.16		0.15	0.16		0.15	0.16		0.15	0.16	
	5.8	Max. gradeability, laden/unladen ⁽⁶⁾	%	12	18		12	18		12	18		10	15	
	5.9	Acceleration time (10m), laden/unladen ^{(4) (6)}	s	4	6		4	6		4	6		4	6	
5.10	Service brake		Electric / el.magn.			Electric / el.magn.			Electric / el.magn.			Electric / el.magn. / hyd.			
Power Unit	6.1	Drive motor rating S2 60 minute rating	kW	6.4			6.4			6.4			6.4		
	6.2	Lift motor rating S3 25% rating	kW	14			14			14			14		
	6.3	Battery according to DIN 43531/35/36 A, B, C, no		43531 C			43531 C			43531 C			43531 C		
	6.4	Battery voltage/capacity 5 hours rate	V/Ah	48/420	48/560	48/700	48/420	48/560	48/700	48/420	48/560	48/700	-	48/560	48/700
	6.5	Battery weight (+/- 5%)	kg	750 - 1200			750 - 1200			750 - 1200			940 - 1200		
	6.6	Consumptions according to VDI cycle	kWh/h	/			/			/			/		
Other	8.1	Drive control		AC ~ MOSFET			AC ~ MOSFET			AC ~ MOSFET			AC ~ MOSFET		
	8.2	Working pressure for attachments	bar	140			140			160			160		
	8.3	Oil flow for attachments	l / min	20			20			20			20		
	8.4	Average noise level at operator's ear	dB (A)	< 70			< 70			< 70			< 70		

¹⁾ With top protection + 20mm.

²⁾ Seat stroke +/- 30mm, intermediate step 380mm, floor plate 560mm.

³⁾ Dimension with Fork L = 1200mm.

⁴⁾ Acceleration 3 preset values available selected by the operator - soft, medium, hard.

⁵⁾ Values refer to a truck equipped with lowest mast, and minimum battery quoted in price list.

⁶⁾ Traction, lift, lower, and reach speeds may vary with specified lift height.

⁷⁾ Values determined by wheel friction. If climbing ramps frequently (within 1 hour), refer to Yale Dealer.

⁸⁾ With beacon h6 + 120mm. For HD + 130mm.

⁹⁾ With overhead guard width 1100mm.

¹⁰⁾ With top protection +13mm.

¹¹⁾ Value refers to a truck equipped with the highest mast and the minimum battery quoted in the price list.

MR Series

Models: MR14, MR14H, MR16, MR16H, MR16N, MR20, MR20H, MR20W, MR25

Operator's compartment and steering

A large dimensioned intermediate step and padded handgrip facilitate easy on/off access. The spacious compartment affords generous leg and head room. A padded headrest is featured on the overhead guard upright.

The full suspension seat is adjustable for the operator's weight, fore/aft position and backrest angle. The steering console is easily adjustable for length, tilt and plane to provide the optimum position for the operator. A release lever with gas spring allows the console to be raised to facilitate frequent on / off access. The steering console incorporates the steering wheel, display with keypad and function buttons for parking brake, 3 preset performance levels plus slow speed mode, and optional features such as traction cut-out override for battery change, 5th hydraulic function and load weight sensor.

The standard fly by wire steering features 360° rotation of the drive wheel for enhanced truck manoeuvrability. As an option 180° steering is offered. Speed reduction on cornering is automatic and can be adjusted. Steering sensitivity is automatically reduced as travel speed increases for enhanced straight line travel control over long distances. The padded steering wheel complete with spinner knob is housed in the adjustable console. Contoured left wrist rest provides a comfortable support to alleviate build-up of fatigue.

Foot controls are laid out in automotive style. The large dimensioned accelerator pedal provides a generous contact area and rest angle to minimise fatigue. The foot brake works electrically on the MR14 and MR16 models. On the MR20, MR20H and MR25 models the foot brake also works hydraulically on the load wheels. Load wheel braking is optional on the MR16/MR16 H versions. A foot presence switch interlocked to traction requires the presence of the left foot. As an option floor mounted forward / reverse direction control via selector switches on the accelerator pedal is available (180° steering only).

Display

A comprehensive easy to read graphic display is provided featuring drive wheel position indicator with forward / reverse travel direction indicator, battery discharge indicator, hourmeter on power up, parking brake status, battery release status, selected performance level and alarm condition. A height indicator display is optional. The display may also be changed to show the alarm history detail or set up parameters. The 10 digit keypad can be configured for driver authorisation codes and the optional height preselector.

CANbus

The MR series features CANbus technology. With this proven technology used in the automobile sector point to point wiring is greatly reduced. Wiring harnesses are significantly simplified and reliability improved. Data transmission reliability using serial communication is enhanced. Service technicians can access any of the controllers or system computer via a single terminal with a handset or laptop to view the alarm history, run diagnostics or adjust performance settings.

Hydraulic controls

The PalmTech joystick is standard. All controls can be readily accessed with minimum hand movement. The primary hydraulic functions for lift / lower and reach / retract are operated by the 4 axis movement of the joystick. Diagonal movement provides simultaneous function operation for speedier load handling. Sideshift and fork tilt operation are actuated by rocker switches located on top of the joystick. Forward / reverse travel direction is selected by a contoured thumb actuated rocker switch. The horn switch is conveniently located under the little finger. A contoured sliding armrest provides support for the operator's forearm. Spring loaded it returns automatically to the rest position on release. As an option individual 4 lever control with a rocker switch for forward/ reverse travel direction and separate horn button is available.

Mast

Three stage full free lift masts with tilting carriage, integral sideshift and load back rest are offered as

standard. The mast design with offset free lift cylinder and the widened inside window combined with angled cross bracing and high visibility fork carriage offer excellent visibility conditions through and past the mast for optimum load handling at different levels. The mast carriage features slow down and stop on reach and retract for smooth jolt free operation. With the mast carriage fully extended truck travel speed is automatically reduced. A height indicator and height pre-selector are available as an option and feature automatic speed slow down with raised forks. The load arms feature bolt-on replaceable wear strips. Front and side load wheel protection is featured as standard. Top side protection for handling pallets crossways over the load wheels is available as an option.

Traction motor and control

A powerful AC drive motor is standard across the model range. The drive motor remains in a fixed position to avoid flexing of the power cables. AC technology eliminates brushes and commutator as well as forward / reverse contactors for minimum motor maintenance. AC technology delivers high motor efficiency, powerful acceleration and braking torque as well as fast travel speed performance both laden and empty. The steering motor also uses AC technology and the gear on gear arrangement provides a positive mesh for precise steering control. On power up the drive wheel is automatically centred. A removable plate allows access to the drive tyre / gear reducer for servicing. The motor compartment including the hoist motor is ventilated.

The inverter converts DC current from the battery into AC current. It features adjustable parameter settings using a handset or laptop and includes self diagnostics and alarm history memory as well as thermal protection. The inverter compartment is fan cooled.

Pump motor and control

The high performance AC pump motor is mounted on isolation pads for reduced vibration and noise. Hydraulic speeds are regulated by the RPM of the pump motor which controls the flow of oil. The hydraulic

block is located at the base of the mast to reduce the length of hydraulic lines and potential maintenance. A microprocessor controls the electro-hydraulic valves. The inverter control provides energy efficient low noise operation. Hydraulic function performance can be adjusted by the technician.

Brakes

Normal electric service braking can be applied by releasing the accelerator pedal, changing travel direction or pressing the brake pedal. Regenerative braking is standard during all these conditions.

The braking force is adjustable. Hydraulic load wheel braking is available as standard on the MR20 / 20H / 25 and optional on the MR16 and MR16H. A powerful electromagnetic brake is used for the parking brake. It is activated automatically when the parking switch is applied, accelerator pedal is released, or the operator removes his foot from the foot presence switch.

Options

A comprehensive selection of options is available including;

- Cold store protection
- PVC seat
- Heated seat
- Height indicator
- Height pre-selector
- Foot direction control
- 180° steering
- 4 lever hydraulic control
- Side battery removal
- Load wheel brakes (MR16/MR16H)
- 5th hydraulic function
- Load weight indicator
- Flashing light
- Work lights
- Fork lowering cut-out



NACCO Materials Handling Limited trading as **Yale Europe Materials Handling**
 Flagship House, Reading Road North, Fleet, Hampshire GU51 4WD, United Kingdom.
 Tel: + 44 (0) 1252 770700 Fax: + 44 (0) 1252 770784
www.yale-forklifts.eu

Country of Registration: England. Company Registration Number: 02636775



Safety. This truck conforms to the current EU requirements. Specification is subject to change without notice.

Publication part no. 258985541 Rev.05
 Printed in The United Kingdom (0709HG) EN

Yale is a registered trade mark.
 © Yale Europe Materials Handling 2009. All rights reserved.

Truck shown with optional equipment