

## Models: MS12S, MS15S

### Operator's compartment and controls

A textile padded seat adjustable for rake provides firm support over long travel distances. A padded armrest and headrest enhance operator comfort. The wide chassis width offers generous leg room.

The electronic fly by wire steering requires zero effort and allows rapid manoeuvring. It can be adjusted for hardness to suit driver preference. A spinner knob is standard. The short steering column is adjustable for tilt.

Travel direction is selected via a rocker switch located on the dash board. The horn is conveniently located beside the direction switch. A mini lever provides responsive fingertip control of the lifting and lowering functions.

The floor presence switch enables traction. Releasing the floor presence switch automatically applies the electromagnetic brake.

### Chassis

The chassis provides fully enclosed protection for the drive train and battery. Provision for side battery extraction featuring battery rollers is standard. The battery retention device does not require any special tools. The battery compartment offers a maximum battery size up to 460 Ah. Battery removal options include a single bed table and a twin bed trolley for battery changing.

Swing open door and removable plates provide access to traction, pump and steering motors.

### Mast

2 stage clearview masts are featured on all models. Rollers are permanently lubricated and sealed for maximum service life. Masts are bolt-on type. A wire mesh guard is fitted as standard.

A transparent guard is available as an option. A variety of mast types including 2 stage and 3 stage with full free lift is offered. Tandem load wheels are standard.

### Traction and pump control

A new generation MOSFET high frequency COMBI controller is used to regulate both traction and pump operation. Energy efficient, smooth progressive control is available at all times.

The controller features automatic braking (reverse current braking) and regenerative braking as well as antirollback start-up on an incline. Automatic speed reduction when cornering is activated via the controller. The speed reduction can be adjusted for angle and force of braking. Using a plug-in console the controller can be adjusted for forward and reverse travel speeds, reverse current braking, release braking, acceleration and speed reduction when cornering. The controller features an in-built diagnostic system and alarm history as well as thermal protection.

### Drive unit

The separately excited (SEM) drive motor delivers fast travel speeds in the laden/unladen condition, high start-up torque and acceleration as well as efficient running. The use of SEM motor technology eliminates forward and reverse contactors. The motor is mounted vertically for easy brush access, improved ventilation and minimum contamination from floor conditions. It is flanged directly on to a helical gear transmission running in an oil bath. The motor is fixed to reduce flexing stress to the power cables. Drive wheel is mounted automobile style to the wheel hub for easy changing.

### Hydraulics

A heavy duty motor drives the pump. Inputs to the motor and proportional valve are received from the controller to control lifting and lowering performance. Lift speed is regulated by the RPM of the pump motor. Lowering speed is controlled by the proportional valve. A flow control valve regulates lowering speeds and a protection valve

prevents further lowering of the mast in the event of a line break.

### Brake

The electromagnetic brake is electrically released and spring applied. Reverse current braking is applied by inverting the direction of travel.

The electromagnetic brake is opened and closed by the accelerator pedal with the foot presence switch depressed. The brake pedal hydraulically activates the electromagnetic brake. The brake is closed by lifting the foot off the foot presence switch.

### Instrumentation

A steering wheel position indicator and a combined hourmeter/battery discharge indicator with lift interrupt are featured on the instrument panel. The indicator also displays alarm conditions should they occur. A quick disconnect traction cut-out button is mounted on the dashboard.

### Options

A comprehensive range of options including mast options, tyre options, side battery removal table, battery change trolley and flashing beacon are available.

Initial lift and straddle versions of the MS12S/MS15S are also available in the range.



**NACCO Materials Handling Limited**  
trading as **Yale Europe Materials Handling**  
Flagship House, Reading Road North,  
Fleet, Hampshire GU51 4WD, United Kingdom.  
Tel: + 44 (0) 1252 770700 Fax: + 44 (0) 1252 770784  
www.yale-europe.com

Country of Registration: England. Company Registration Number: 02636775



**Safety.** This truck conforms to the current EU requirements. Specification is subject to change without notice

Publication part no. 258980280 Rev.02  
Printed in The United Kingdom (050877HG) EN

Yale is a registered trade mark.  
© Yale Europe Materials Handling 2008. All rights reserved.

Truck shown with optional equipment

## Seated Rider Stacker 1,250kg and 1,500kg

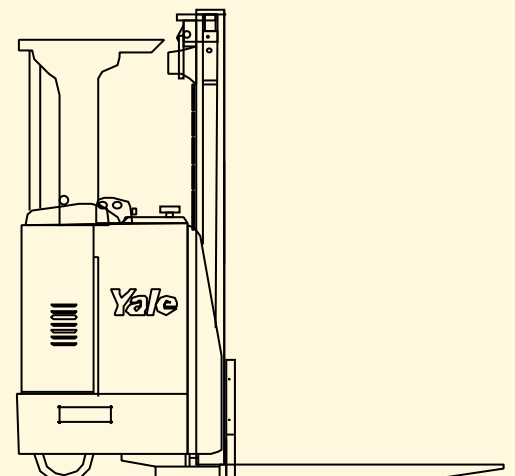

- Panorama mast
- MOSFET traction control
- Automatic release braking
- Regenerative braking
- Side stabiliser option for increased residual capacity/high lift

## Truck Dimensions

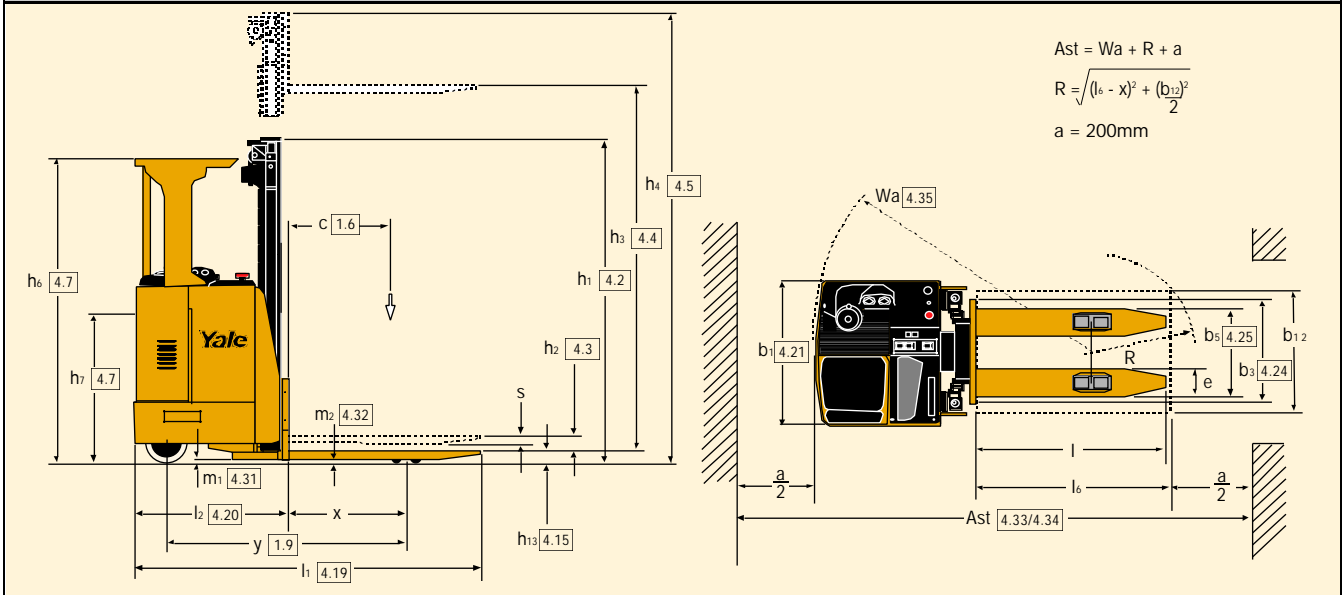

## Mast details - MS12S, MS15S

Mast type	Overall lowered height ( $h_1$ ) mm	Lift height ( $h_3$ ) mm	Maximum fork height ( $h_3 + h_{13}$ ) mm	Overall extended height ( $h_4$ )* mm	Free lift ( $h_2$ ) mm
2-stage High Vis.	1920	2965	3050	3535	100
	2120	3365	3450	3935	100
	2320	3765	3850	4335	100
	2520	4165	4250	4735	100
3-stage Full Free Lift	1820	4025	4110	4590	1255
	1920	4325	4410	4890	1355
	2020	4625	4710	5190	1455

\* with load backrest + 530mm.  
Additional mast heights available on request.

## VDI 2198 - General Specifications

		Yale	Yale	Yale	Yale		
Characteristics	1.1	Manufacturer	Yale	Yale	Yale		
	1.2	Model designation	<b>MS12S (2 stage mast)</b>	<b>MS12S (3 stage mast)</b>	<b>MS15S (2 stage mast)</b>	<b>MS15S (3 stage mast)</b>	
	1.3	Power: Battery, Diesel, LPG, Electric mains	Battery	Battery	Battery	Battery	
	1.4	Operation	Seated	Seated	Seated	Seated	
	1.5	Load capacity	Q (t)	1.25	1.25	1.5	1.5
	1.6	Load centre	c (mm)	600	600	600	600
	1.8	Load distance	x (mm)	712	694	712	694
	1.9	Wheelbase	y (mm)	1485	1485	1485	1485
	Weights	2.1	Unladen weight	kg	1470	1570	1470
2.2		Axle loading laden, front/rear	kg	1020 / 1700	1070 / 1750	1060 / 1910	1100 / 1970
2.3		Axle loading unladen, front/rear	kg	920 / 550	960 / 610	920 / 550	960 / 610
Wheels and Tyres	3.1	Tyres - rubber, Vulkollan, front/rear		Vulkollan	Vulkollan	Vulkollan	Vulkollan
	3.2	Tyre size - front		Ø 254 x 127	Ø 254 x 127	Ø 254 x 127	Ø 254 x 127
	3.3	Tyre size - rear		Ø 85 x 70	Ø 85 x 70	Ø 85 x 70	Ø 85 x 70
	3.4	Additional wheels (dimensions)		Ø 180 x 75	Ø 180 x 75	Ø 180 x 75	Ø 180 x 75
	3.5	Wheels - number front/rear (x = driven)		2x / 4	2x / 4	2x / 4	2x / 4
	3.6	Track width - front	b10 (mm)	635	635	635	635
	3.7	Track width - rear	b11 (mm)	380	380	380	380
Dimensions	4.2	Height of mast, lowered	h1 (mm)	see table	see table	see table	see table
	4.3	Free lift	h2 (mm)	see table	see table	see table	see table
	4.4	Lift height	h3 (mm)	see table	see table	see table	see table
	4.5	Height of mast extended	h4 (mm)	see table	see table	see table	see table
	4.7	Overhead guard height	h6 (mm)	2000	2000	2000	2000
	4.8	Seat height	h7 (mm)	975	975	975	975
	4.15	Lowered height	h13 (mm)	85	85	85	85
	4.19	Overall length	l1 (mm)	2135	2155	2135	2155
	4.20	Length to front face of forks	l2 (mm)	975	995	975	995
	4.21	Overall width	b1/b2 (mm)	960	960	960	960
	4.22	Fork dimensions	s/e/l (mm)	65 / 180 / 1160	65 / 180 / 1160	65 / 180 / 1160	65 / 180 / 1160
	4.24	Fork carriage width	b3 (mm)	675	675	675	675
	4.25	Outside fork width	b5 (mm)	570	570	570	570
	4.31	Ground clearance beneath mast, laden	m1 (mm)	20	20	20	20
	4.32	Ground clearance, centre of wheelbase	m2 (mm)	20	20	20	20
4.33	Aisle width for pallets 1000 x 1200 wide	Ast (mm)	2575	2582	2575	2582	
4.34	Aisle width for pallets 800 x 1200 long	Ast (mm)	2540	2555	2540	2555	
4.35	Turning radius	Wa (mm)	1710	1710	1710	1710	
Performance	5.1	Travel speed, laden/unladen	Km/h	8 / 9	8 / 9	8 / 9	8 / 9
	5.2	Lift speed, laden/unladen	m/s	0.18 / 0.22	0.18 / 0.22	0.15 / 0.22	0.15 / 0.22
	5.3	Lowering speed, laden/unladen	m/s	0.30 / 0.25	0.30 / 0.25	0.30 / 0.25	0.30 / 0.25
	5.8	Max. gradeability, laden/unladen	%	8 / 10	8 / 10	8 / 10	8 / 10
	5.10	Service brake		Electromagnetic / Hydr.	Electromagnetic / Hydr.	Electromagnetic / Hydr.	Electromagnetic / Hydr.
Motors	6.1	Drive motor rating (S2 60 min)	kW	2.6	2.6	2.6	2.6
	6.2	Lift motor rating (S3 15%)	kW	3	3	3	3
	6.3	Battery to DIN 43531/35/36 A, B, C, no		43531 A	43531 A	43531 A	43531 A
	6.4	Battery voltage/capacity (5 hour rate)	V/Ah	24 / 460	24 / 460	24 / 460	24 / 460
	6.5	Battery weight	kg	350	350	350	350
Other	8.1	Drive control		MOSFET	MOSFET	MOSFET	MOSFET