

VL Series

Electric Forklift Trucks with AC Technology

2,200kg, 2,500kg, 3,000kg and 3,500kg



- HiP and eLo performance settings
- YaleStop automatic park brake
- Lowest whole body vibration (WBV) levels
- Continuous stability enhancement (CSE)
- Oil-immersed brakes
- CANbus technology

Yale 
People. Products. Productivity.

Truck Dimensions

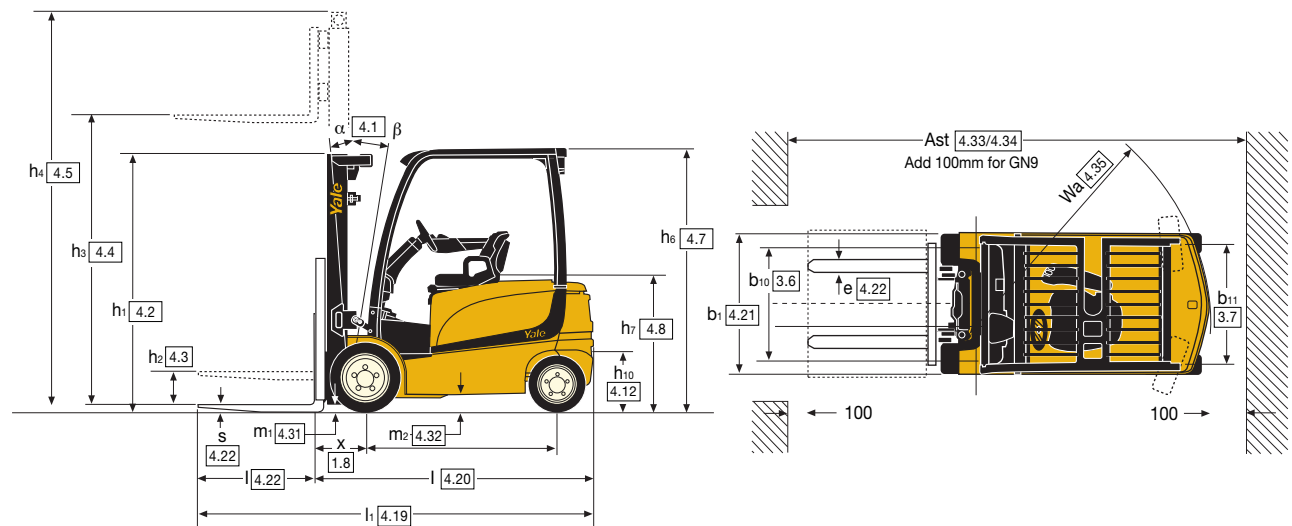

ERP22 VL, 25 VL SWB, 25 VL LWB mast details and capacity ratings (kg) - Supercushion tyres

Model					ERP 22 VL									ERP 25 VL SWB						ERP 25 VL LWB					
Tyres					23x10-12									23x10-12						23x10-12					
Width across tyres					1173mm									1173mm						1173mm					
Masts	OAH	FFH	MFH	Tilt	Forks			Integral Sideshift			Forks			Integral Sideshift			Forks			Integral Sideshift					
					h1	h2+s	h3+s	h4	F	B	500	600	700	500	600	700	500	600	700	500	600	700	500	600	700
2 Stage LFL (V)	2195	140	3390	3956	5	5	2200	2000	1900	2200	2000	1830	2500	2270	2140	2490	2250	2060	2500	2270	2170	2500	2270	2090	
	2395	140	3790	4356	5	5	2200	2000	1900	2200	2000	1820	2500	2270	2130	2490	2250	2050	2500	2270	2170	2500	2270	2090	
	2745	140	4330	4896	5	5	2200	2000	1890	2200	1990	1810	2500	2270	2120	2470	2250	2040	2500	2270	2160	2500	2270	2080	
	2995	140	4830	5396	5	5	2200	2000	1880	2190	1980	1800	2480	2250	2090	2440	2210	2010	2500	2270	2150	2500	2270	2070	
2 Stage FFL (F)	2195	1625	3400	3966	5	5	2200	2000	1900	2200	2000	1830	2500	2270	2140	2500	2260	2060	2500	2270	2170	2500	2270	2090	
	2395	1825	3800	4366	5	5	2200	2000	1890	2200	2000	1820	2500	2270	2130	2490	2250	2050	2500	2270	2160	2500	2270	2090	
	2745	2175	4420	4986	5	5	2200	2000	1880	2200	1990	1810	2500	2270	2120	2480	2240	2040	2500	2270	2150	2500	2270	2070	
3 Stage FFL (E)	2145	1595	4950	5496	5	5	2200	2000	1870	2180	1970	1790	2440	2210	2060	2400	2170	1980	2500	2270	2140	2500	2250	2060	
	2395	1845	5550	6096	5	5	2110	1920	1780	2070	1870	1700	2310	2100	1930	2250	2030	1850	2410	2190	2050	2380	2150	1960	
	2595	2045	6000	6546	5	5	2020	1830	1700	1980	1790	1630	2210	2000	1840	2150	1940	1770	2310	2100	1960	2290	2070	1890	

ERP30 VL, ERP35 VL mast details and capacity ratings (kg) - Supercushion tyres

Model					ERP 30 VL									ERP 35 VL					
Tyres					23x10-12									23x10-12					
Width across tyres					1173mm									1173mm					
Masts	OAH	FFH	MFH	Tilt	Forks			Integral Sideshift			Forks			Integral Sideshift					
					h1	h2+s	h3+s	h4	F	B	500	600	700	500	600	700	500	600	700
2 Stage LFL (V)	2195	145	3200	3861	5	5	3000	2720	2550	2960	2680	2440	3500	3130	2680	3440	3110	2680	
	2395	145	3600	4261	5	5	3000	2720	2540	2950	2670	2440	3500	3130	2680	3430	3100	2680	
	2745	145	4100	4761	5	5	3000	2720	2530	2940	2660	2430	3500	3130	2680	3420	3090	2680	
	2995	145	4600	5261	5	5	2920	2650	2460	2850	2580	2360	3410	3090	2680	3330	3010	2680	
2 Stage FFL (F)	2195	1535	3205	3862	5	5	3000	2720	2550	2960	2680	2440	3500	3130	2680	3440	3110	2680	
	2595	1935	3905	4562	5	5	3000	2720	2530	2940	2660	2430	3500	3130	2680	3420	3090	2680	
	2845	2185	4405	5062	5	5	2960	2680	2500	2900	2620	2390	3450	3130	2680	3370	3050	2680	
3 Stage FFL (E)	2145	1500	4610	5252	5	5	2970	2690	2500	2900	2620	2390	3460	3130	2680	3370	3050	2680	
	2295	1650	4910	5552	5	5	2900	2630	2440	2830	2560	2340	3400	3080	2680	3300	2980	2680	
	2395	1750	5210	5852	5	5	2840	2570	2380	2760	2500	2280	3320 *	3010 *	2680 *	3220 *	2920 *	2660 *	
	2645	2000	5810	6452	5	5	2690	2440	2250	2600	2350	2150	3170 *	2870 *	2640 *	3060 *	2760 *	2520 *	

All capacities calculated with 1000mm long forks and are less load backrest.
* Wide Tread Required

VDI 2198 - General Specifications

Characteristics	1.1	Manufacturer		Yale	Yale	Yale	Yale	Yale							
	1.2	Model designation		ERP 22 VL SWB	ERP 25 VL SWB	ERP 25 VL LWB	ERP 30 VL LWB	ERP 35 VL LWB							
		Model -Manufacturers designation		Value	Value	Value	Value	Value	Value						
	1.3	Drive: electric		Battery	Battery	Battery	Battery	Battery	Battery						
	1.4	Operation		Seated	Seated	Seated	Seated	Seated	Seated						
	1.5	Load capacity	Q (t)	2200	2500	2500	3000	3500							
	1.6	Load centre	c (mm)	500	500	500	500	500	500						
	1.8	Load distance	x (mm)	404	404	404	416	416							
	1.9	Wheelbase	y (mm)	1606	1606	1750	1750	1750							
Weights	2.1	Unladen weight (max. battery)	kg	4465	4465	4876	4910	5225							
	2.2	Axle loading laden, front/rear (max. battery)	kg	5651	1014	6120	845	6195	1181	7006	904	7714	1011		
	2.3	Axle loading unladen, front/rear (max. battery)	kg	2212	2253	2212	2253	2403	2473	2443	2467	2391	2834		
Wheels & Tyres	3.1	Tyres: P=pneumatic, C=cushion, SC=supercushion		SC	SC	SC	SC	SC							
	3.2	Tyre size, front		23 x 10 - 12	23 x 10 - 12	23 x 10 - 12	23 x 10 - 12	23 x 10 - 12							
	3.3	Tyre size, rear		18 x 7 - 8	18 x 7 - 8	18 x 7 - 8	18 x 7 - 8	18 x 7 - 8							
	3.5	Number of wheels, front/rear (X = driven)		2X	2	2X	2	2X	2	2X	2	2X	2		
	3.6	Track width, front.	b10 (mm)	938	1054	938	1054	938	1054	938	1054	938	1054		
	3.7	Track width, rear	b11 (mm)	992		992		992		992		992			
	Dimensions	4.1	Mast tilt, forward α /back β	degrees	5	5	5	5	5	5	5	5	5		
4.2		Height of mast, lowered	h1 (mm)	2192		2192		2192		2192		2192			
4.3		Free lift ▼	h2 (mm)	100		100		100		100		100			
4.4		Lift height ▼	h3 (mm)	3350		3350		3350		3155		3155			
4.5		Height of mast, extended +	h4 (mm)	3960		3960		3960		3865		3865			
4.7		Height to top of overhead guard ○	h6 (mm)	2193		2193		2193		2193		2193			
4.8		Seat height x ○	h7 (mm)	1069		1069		1069		1069		1069			
4.12		Towing coupling height	h10 (mm)	262		262		262		262		262			
4.19		Overall length	l1 (mm)	3321		3321		3465		3465		3555			
4.20		Length to face of forks	l2 (mm)	2321		2321		2465		2465		2555			
4.21		Overall width	b1/b2 (mm)	1173	1289	1173	1289	1173	1289	1173	1289	1173	1289		
4.22		Fork dimensions	s/e/l (mm)	40	100	1000	40	100	1000	40	100	1000	45	100	1000
4.23		Fork carriage DIN 15173. Class, A/B		2A		2A		2A		3A		3A			
4.24		Fork carriage width ▶	b3 (mm)	1067		1067		1067		1067		1067			
4.31		Ground clearance under mast, laden	m1 (mm)	98		98		98		98		98			
4.32		Ground clearance at centre of wheelbase	m2 (mm)	137		137		137		137		137			
4.33		Aisle width with pallets 1000 long x 1200 wide	Ast (mm)	3598		3598		3736		3747		3813			
4.34		Aisle width with pallets 800 wide x 1200 long	Ast (mm)	3751		3751		3891		3903		3969			
4.35	Outer turning radius	Wa (mm)	1931		1931		2073		2073		2139				
4.36	Inner turning radius	b13 (mm)	173		173		189		189		189				
Performance	5.1	Travel speed laden/unladen	Kmh	18.0	18.0	18.0	18.0	18.0	17.0	18.0	16.0	18.0			
	5.2	Lifting speed laden/unladen	m/sec	0.40	0.63	0.38	0.63	0.38	0.63	0.33	0.59	0.31	0.59		
	5.3	Lowering speed laden/unladen	m/sec	0.57	0.51	0.57	0.51	0.57	0.51	0.56	0.46	0.58	0.46		
	5.5	Drawbar pull laden/unladen, 60 min. rating	N	5468	5773	5591	5726	5591	5726	5441	5588	5478	5720		
	5.6	Max. drawbar pull laden/unladen, 5 min. rating	N	18045	19052	18451	18897	18451	18897	17956	18441	18076	18875		
	5.7	Gradeability laden/unladen, 30 min. rating	%	10	14	9	13	9	13	8	12	7	12		
	5.8	Max. gradeability laden/unladen, 5 min. rating	%	26	39	24	35	24	35	22	34	20	32		
	5.9	Acceleration time laden/unladen	sec	4.42	4.11	4.45	4.11	4.45	4.11	4.56	4.18	4.60	4.23		
	5.10	Service brake		Hydraulic		Hydraulic		Hydraulic		Hydraulic		Hydraulic			
	Motor	6.1	Drive motor output, (S2 60 minute rating)	kW	2x 10.0		2x 10.0		2x 10.0		2x 10.0		2x 10.0		
6.2		Lifting motor, (S3 15% rating)	kW	16.0		16.0		16.0		16.0		16.0			
6.3		Battery DIN 43531/35/36 A, B, C, no		43536A		43536A		43536A		43536A		43536A			
6.4		Battery voltage/capacity at 5hr rate	V/Ah	80	620	80	620	80	775	80	775	80	775		
6.5		Battery weight (min/max)	kg	1635		1635		1955		1955		1955			
6.6		Power consumption in accordance with VDI cycle	kWh/h	6.68		7.00		7.89		8.66		10.03			
Other	8.1	Drive control		AC electronic		AC electronic		AC electronic		AC electronic		AC electronic			
	8.2	Working pressure for attachments	bar	155		155		155		155		155			
	8.3	Oil flow for attachments, manual hydraulics †	l/min	20-40		20-40		20-40		20-40		20-40			
	8.4	Average noise level at operator's ear ★	dB (A)	67		67		67		67		67			
	8.5	Towing coupling type		Pin		Pin		Pin		Pin		Pin			

★ L_{50/2} measured according to the test cycles and based on the weighting values contained in EN12053.

† Maximum flow set through dash display.

▼ Bottom of forks.

✘ Full Suspension specified. Compressed condition, add 40mm for nominal position.

✚ Without load backrest.

▶ Add 28mm with load backrest.

○ h6 subject to +/- 5mm tolerance. Add 104mm for battery side removal option.

Specification Sheet based on trucks with: Standard seat, overhead guard, standard carriage, 1000 mm forks with load backrest, eLo setting with DIN battery configuration, 2 stage LFL mast :- ERP20-25VL - 3390 mm, ERP30-35VL - 3200 mm.

VL Series

Models: 22VL, 25VL SWB and LWB, 30VL and 35VL

AC Technology

Yale AC technology Class H traction motors are suitable for the most arduous applications. Smooth forward and reverse directional changes provide seamless driving action. In the high-performance or 'HiP' setting, AC technology provides increased acceleration, even when fully laden and on gradients. As well as improving performance, AC technology reduces maintenance and allows service intervals of 1000 hours for most components.

Brakes

The truck is equipped with oil immersed brakes and YaleStop™ an automatic park brake spring applied, electro magnetically released park brake. The park brake is automatically set by the control system, so that the brake is always set whenever the truck is not moving, and no traction has been requested. Moreover the park brake provides controllability on ramp applications.

When the footbrake is applied the intelligent control system uses 'e-Boost' which increases the strength of the 'autoregen' function of the traction motors. This also decreases the amount of work executed by the oil immersed disc brakes resulting in reduced wear on the brakes.

Steering

A 16 KW AC motor drives a pump which provides oil pressure for the hydraulic pump and for steering, eliminating the need for a separate steering motor and pump. The steering column is infinitely adjustable in a range of 26°. During cornering the speed of the drive motors is continuously adjusted independently by the traction controller ensuring smooth operation. The Yale VL features a state-of-the-art extended steer-axle that has increased articulation of the steer wheels, allowing it to turn in smaller spaces than a conventional 4-wheel steer-axle.

Performance modes

Performance of the truck can be tailored via the enhanced overhead display, with 4 performance modes available to suit the requirements of the application or the preferences of the driver. For maximum speed and acceleration, choose mode 4, or for

more delicate maneuvering and extended battery life, mode 1 is ideal. Your service technician can alter the top speed and acceleration of mode 4, with modes 1, 2 and 3 being automatically adjusted as percentages of setting 4.

'eLo' and 'HiP' Settings

Yale VL trucks feature an 'eLo' energy saving setting which provides exceptional energy efficient performance when required for continuous operation over longer periods without recharging the battery. The 'HiP' high performance setting (accessible via the dash display with a service password) changes the torque curve characteristics of the motor to give the truck increased torque, faster acceleration and increased speed on a grade for the most demanding applications whilst maintaining the same top speed as the 'eLo' setting. 'eLo' provides maximum battery autonomy.

Improved ergonomics

The VL is designed for optimum operator comfort.

The overhead guard mounted grab handle, seat armrest (hinged) and very low step height provide class leading three point entry and exit to the operator module. The operator is seated in an ergonomically designed position for maximum safety, comfort, visibility and ease of operation. A new full suspension seat provides 80mm of suspension and the lowest WBV levels in the industry. A swivel seat option for a superior reverse driving position is available. Both the mini-lever module and the manual levers have an integrated direction switch. The ergonomically designed gas spring assisted steering column has infinite forward and reverse adjustment through 26°, can be telescopically adjusted by 75mm. Synchronised steering which further increases operator comfort and operation also features steer column memory tilt (option).

The truck also features generous floor and storage space. The clear footwell allows easy access from both sides of the truck when the optional mini lever module fitted.

Continuous Stability Enhancement (CSE)

This is a mechanical system which uses gravity to optimize the design geometry

of the Yale steer axle. It reduces lean by limiting the articulation of the steer axle and does not compromise the trucks ability to operate over poor ground conditions or traverse obstacles. It is also 100% maintenance free.

Masts

A full range of Yale Hi-Vis™ 2 stage LFL and 2 and 3 stage FFL masts are available. Yale Hi-Vis™ masts are designed for maximum visibility, with widely spaced channels, lift chains and main lift cylinders.

Battery

A choice of DIN batteries from 560Ah/620Ah - 700Ah/775Ah (wheelbase dependent) are available.

The short wheelbase model (SWB) has a smaller capacity battery and delivers increased maneuverability and reduced stacking aisle dimensions. The long wheelbase model (LWB) provides extra battery space for longer shift life. A battery discharge indicator (BDI) and lift interrupt are standard on all trucks.

Low lifetime costs

Lower service costs are achieved as a result of less maintenance associated with oil immersed brakes, hall effect sensors, electric park brake and CANbus and AC technology. The transmission is sealed for life, eliminating the need for service, an oil change is required at 4000 hours. LED light packages are offered as an option. Service intervals are 1000 hours for most components and 4000 hours for oil immersed brakes, drive axle, transmission and hydraulic oil. Auto Regen Braking optimises the shift life of the battery and contributes to an increase in the life of parts.

Options

- Accutouch mini-levers
- Return to set tilt (RTST)
- Foot directional control
- Lighting kits, including LED lights
- Reverse alarm
- Integrated sideshift
- Two battery extraction methods:-
 1. Overhead
 2. Side extraction
- Weather protection



NACCO Materials Handling Limited trading as Yale Europe Materials Handling
Flagship House, Reading Road North, Fleet, Hampshire GU51 4WD, United Kingdom.
Tel: + 44 (0) 1252 770700 Fax: + 44 (0) 1252 770784
www.yale-forklifts.eu

Country of Registration: England. Company Registration Number: 02636775



Safety. This truck conforms to the current EU requirements. Specification is subject to change without notice.

Publication part no. 258725914 Rev.00, VDI 00

Printed in The United Kingdom (10090HG) EN

Yale is a registered trade mark.
© Yale Europe Materials Handling 2009. All rights reserved.
Truck shown with optional equipment