

# VT Series

## Electric Forklift Trucks with AC Technology

1,500kg, 1,600kg, 1,800kg and 2,000kg



- YaleStop automatic park brake eliminates uncontrolled roll-back on ramps
- Oil-immersed brakes
- CANbus technology
- High-performance AC motor technology
- 2 battery choices: DIN and BS

# Truck Dimensions

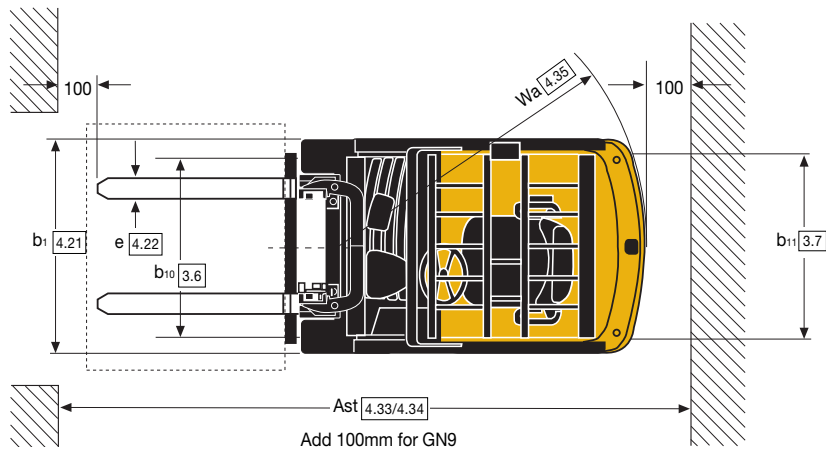
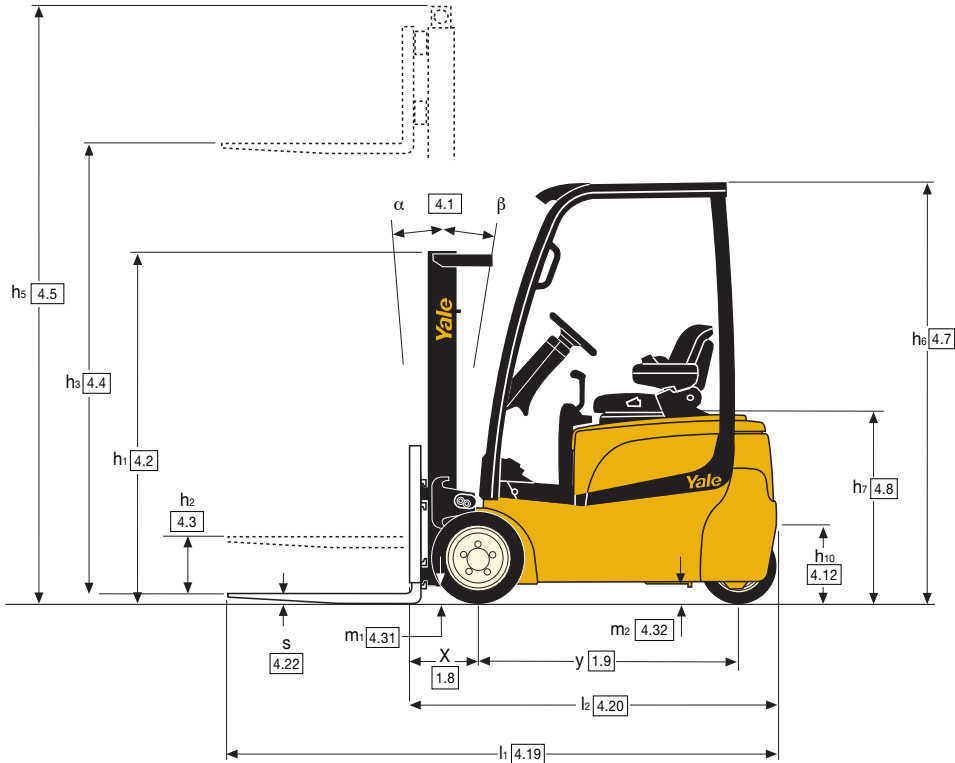

## ERP15 VT SWB Mast details and capacity ratings (kg) - Supercushion tyres

Model		ERP 15 VT SWB										
Tyres		18 x 7-8										
Width across tyres		1050mm										
Masts	OAH	FFH	MFH	h4	Tilt		Forks			Integral Sideshift		
					F	B	Load Centre			Load Centre		
	h1	h2+s	h3+s				500	600	700	500	600	700
2 Stage LFL Clear View	2230	140	3360	3868	5	5	1500	1300	1300	1500	1300	1240
	2580	140	3860	4368	5	5	1500	1300	1300	1500	1300	1230
	2830	140	4360	4868	5	5	1480	1280	1280	1480	1280	1220
	3180	140	4860	5368	5	5	1400	1210	1210	1400	1210	1140
3 Stage FFL Clear View	2080	1572	4600	5108	5	5	1450	1250	1250	1450	1250	1190
	2180	1672	4900	5408	5	5	1400	1210	1200	1400	1210	1140
	2330	1822	5200	5708	5	5	1340	1160	1150	1340	1160	1090
	2430	1942	5500	6008	5	5	1230	1110	1100	1200	1110	1040

# VDI 2198 - General Specifications

Characteristics	1.1	Manufacturer		Yale	Yale	Yale
	1.2	Model designation		<b>ERP 15VT (SWB)</b>	<b>ERP 16VT (SWB)</b>	<b>ERP 16VT (MWB)</b>
	1.3	Drive: Electric		Battery	Battery	Battery
	1.4	Operation		Seated	Seated	Seated
	1.5	Load capacity	Q (kg)	1500	1600	1600
	1.6	Load centre	c (mm)	500	500	500
	1.8	Load distance	x (mm)	326	326	326
	1.9	Wheelbase	y (mm)	1290	1290	1386
	Weights	2.1	Unladen weight (max. battery)	kg	2990	2990
2.2		Axle loading laden, front/rear (max. battery)	kg	3877 / 604	4013 / 540	4062 / 721
2.3		Axle loading unladen, front/rear (max. battery)	kg	1416 / 1566	1491 / 1563	1506 / 1676
Wheels & Tyres	3.1	Tyres: P=pneumatic, C=cushion, SC=supercushion		SC	SC	SC
	3.2	Tyre size - front		18 x 7-8	18 x 7-8	18 x 7-8
	3.3	Tyre size - rear		15 x 4.5-8	15 x 4.5-8	15 x 4.5-8
	3.5	Number of wheels, front/rear (X = driven)		2X / 2	2X / 2	2X / 2
	3.6	Track width, front	b10 (mm)	892	892	892
	3.7	Track width, rear	b11 (mm)	194	194	194
	Dimensions	4.1	Mast tilt, forward $\alpha$ / back $\beta$	degrees	5 / 5	5 / 5
4.2		Height of mast, lowered	h1 (mm)	2090	2230	2130
4.3		Free lift ▼	h2 (mm)	100	100	100
4.4		Lift height ▼	h3 (mm)	3320	3320	3320
4.5		Height of mast, extended +	h4 (mm)	3800	3906	3906
4.7		Height to top of overhead guard	h6 (mm)	2070	2070	2070
4.8		Seat height (raised / lowered) x	h7 (mm)	919	919	919
4.12		Towing coupling height	h10 (mm)	500	500	500
4.19		Overall length	l1 (mm)	2805	2805	2901
4.20		Length to front face of forks	l2 (mm)	1805	1805	1901
4.21		Overall width	b1 (mm)	1050	1050	1050
4.22		Fork dimensions	s/e/l (mm)	40 / 80 / 1000	40 / 80 / 1000	40 / 80 / 1000
4.23		Fork carriage DIN 15173. Class, A/B		2A	2A	2A
4.24		Fork carriage width ▶	b3 (mm)	907	907	907
4.31		Ground clearance under mast, laden	m1 (mm)	88	88	88
4.32		Ground clearance at centre of wheelbase	m2 (mm)	100	100	100
4.33		Aisle width with pallets 1000 long x 1200 wide	Ast (mm)	3131	3131	3230
4.34		Aisle width for pallets 800 wide x 1200 long	Ast (mm)	3254	3254	3353
4.35	Outer turning radius	Wa (mm)	1476	1476	1575	
4.36	Inner turning radius	b13 (mm)	0	0	0	
Performance	5.1	Travel speed laden/unladen Ⓞ	km/h	16 / 16	16 / 16	16 / 16
	5.2	Lifting speed laden/unladen	m/sec	.43 / .47	.43 / .59	.43 / .59
	5.3	Lowering speed laden/unladen	m/sec	.50 / .50	.50 / .47	.50 / .47
	5.5	Drawbar pull laden/unladen, 60 minute rating	N	3406 / 3680	3406 / 3680	3406 / 3680
	5.6	Max. drawbar pull laden/unladen, 5 minute rating	N	11415 / 11690	11415 / 11690	11415 / 11690
	5.7	Gradeability laden/unladen, 30 minute rating	%	11 / 16	11 / 13	11 / 16
	5.8	Max. gradeability, laden/unladen, 5 minute rating	%	25 / 34	25 / 34	25 / 35
	5.9	Acceleration time laden/unladen	sec	4.6 / 4.1	4.6 / 4.1	4.6 / 4.1
	5.10	Service brake		hydraulic	Hydraulic	Hydraulic
	Motor	6.1	Drive motor output (S2 60 minute rating)	kW	2 x 5.0	2 x 5.0
6.2		Lifting motor, (S3 15% rating)	kW	12	12	12
6.3		Battery to DIN 43531/35/36 A, B, C, no		DIN 43531-A	DIN 43531-A	DIN 43531-A
6.4		Battery voltage/capacity at 5hr rate	V/ah	48 / 420-500	48 / 500	48 / 500
6.5		Battery weight (min/max)	kg	673 - 743	673 - 743	673 - 743
6.6		Power consumption in accordance with VDI cycle	kWh/h	7.55	7.55	7.55
Other	8.2	Working pressure for attachments	bar	180	180	180
	8.3	Oil flow for attachments, manual hydraulics ❖	l/min	20-40	20-40	20-40
	8.4	Average noise level at operator's ear	dB (A)	65	65	65
	8.5	Towing coupling type		Pin	Pin	Pin

\*  $L_{max}$  measured according to the test cycles and based on the weighting values contained in EN12053

▼ Bottom of forks

x Full suspension seat (FLM80) specified. Standard Hood specified. 953mm with Raised Hood.

+ Without load backrest

▶ Add 32mm for load backrest

○ h6 subject to +/- 5mm tolerance

❖ Maximum flow through dash display

Ⓞ Extended shift off with e-hydraulics

Yale	Yale	Yale	Yale	Yale	1.1	Characteristics
<b>ERP 16VT (LWB)</b>	<b>ERP 18VT (MWB)</b>	<b>ERP 18VT (LWB)</b>	<b>ERP 20VT (MWB)</b>	<b>ERP 20VT (LWB)</b>	1.2	
Battery	Battery	Battery	Battery	Battery	1.3	
Seated	Seated	Seated	Seated	Seated	1.4	
1600	1800	1800	2000	2000	1.5	
500	500	500	500	500	1.6	
326	321	321	321	321	1.8	
1494	1386	1494	1386	1494	1.9	
3210	3260	3280	3540	3290	2.1	
4005 / 797	4449 / 606	4384 / 691	4895 / 635	4730 / 572	2.2	
1520 / 1682	1582 / 1673	1595 / 1680	1709 / 1822	1616 / 1674	2.3	
SC	SC	SC	SC	SC	3.1	Wheels & Tyres
18 x 7-8	200 / 50-10	200 / 50-10	200 / 50-10	200 / 50-10	3.2	
15 x 4.5-8	15 x 4.5-8	15 x 4.5-8	15 x 4.5-8	15 x 4.5-8	3.3	
2X / 2	2X / 2	2X / 2	2X / 2	2X / 2	3.5	
892	906	906	906	906	3.6	
194	194	194	194	194	3.7	
5 / 5	5 / 5	5 / 5	5 / 5	5 / 5	4.1	Dimensions
2230	2180	2180	2180	2180	4.2	
100	100	100	100	100	4.3	
3320	3390	3390	3390	3390	4.4	
3898	4006	4006	4006	4006	4.5	
2070	2070	2070	2070	2070	4.7	
919	919	919	919	919	4.8	
500	500	500	500	500	4.12	
3004	2896	2999	2896	2999	4.19	
2004	1896	1999	1896	1999	4.20	
1050	1116	1116	1116	1116	4.21	
40 / 80 / 1000	40 / 80 / 1000	40 / 80 / 1000	40 / 100 / 1000	40 / 100 / 1000	4.22	
2A	2A	2A	2A	2A	4.23	
907	977	977	977	977	4.24	
88	88	88	88	88	4.31	
100	100	100	100	100	4.32	
3331	3226	3327	3226	3327	4.33	
3454	3348	3449	3348	3449	4.34	
1676	1575	1676	1575	1676	4.35	
0	0	0	0	0	4.36	
16 / 16	16 / 16	16 / 16	16 / 16	16 / 16	5.1	Performance
0.43 / 0.60	0.41 / 0.58	0.41 / 0.58	0.40 / 0.58	0.40 / 0.58	5.2	
0.50 / 0.48	0.46 / 0.40	0.46 / 0.50	0.47 / 0.40	0.47 / 0.40	5.3	
3406 / 3680	3337 / 3646	3337 / 3646	3260 / 3603	3294 / 3637	5.5	
11415 / 11690	11355 / 11664	11346 / 11655	11269 / 11612	11304 / 11647	5.6	
11 / 16	10 / 15	10 / 15	9 / 14	9 / 15	5.7	
25 / 35	23 / 35	23 / 36	31 / 34	22 / 36	5.8	
4.6 / 4.1	4.6 / 4.1	4.6 / 4.1	4.6 / 4.1	4.6 / 4.1	5.9	
Hydraulic	Hydraulic	Hydraulic	Hydraulic	Hydraulic	5.10	
2x 5.0	2x 5.0	2x 5.0	2x 5.0	2x 5.0	6.1	Motor
12	12	12	12	12	6.2	
DIN 43531-A	DIN 43531-A	DIN 43531-A	DIN 43531-A	DIN 43531-A	6.3	
48 / 750	48 / 625	48 / 750	48 / 625	48 / 750	6.4	
962 / 1064	813 / 899	962 / 1064	813 / 899	962 / 1064	6.5	
7.55	7.78	7.78	7.78	7.78	6.6	
180	180	180	180	180	8.2	Other
20-40	20-40	20-40	20-40	20-40	8.3	
65	65	65	65	65	8.4	
Pin	Pin	Pin	Pin	Pin	8.5	

**Spec sheet truck based on:**  
3360mm (Clear View) and 3430mm (Hi-Vis) to top of fork, 2 stage LFL mast with standard carriage and 1000mm forks, with HiP performance setting, DIN battery configuration.

### ERP16 VT SWB/MWB/LWB mast details and capacity ratings (kg) - Supercushion tyres

Model					ERP 16 VT SWB							ERP 16 VT MWB							ERP 16 VT LWB								
Tyres					18 x 7-8							8 x 7-8							8 x 7-8								
Width across tyres					1050mm							1050mm							1050mm								
Masts	OAH	FFH	MFH	h4	Tilt		Forks			Integral Sideshift				Forks			Integral Sideshift				Forks			Integral Sideshift			
					F	B	Load Centre			Load Centre				Load Centre			Load Centre				Load Centre			Load Centre			
	h1	h2+s	h3+s				500	600	700	500	600	700	500	600	700	500	600	700	500	600	700	500	600	700			
2 Stage LFL Clear View	2230	140	3360	3868	5	5	1600	1350	1350	1600	1350	1320	1600	1350	1350	1600	1350	1320	1600	1350	1350	1600	1350	1320			
	2580	140	3860	4368	5	5	1600	1350	1350	1600	1350	1310	1600	1350	1350	1600	1350	1310	1600	1350	1350	1600	1350	1310			
	2830	140	4360	4868	5	5	1580	1330	1330	1540	1330	1290	1580	1330	1330	1580	1330	1290	1580	1330	1330	1580	1330	1290			
	3180	140	4860	5368	5	5	1490	1260	1260	1470	1260	1210	1500	1260	1260	1500	1260	1220	1500	1260	1260	1500	1260	1220			
2 Stage LFL Hi-Vis	2180	140	3430	4006	5	5	1600	1350	1350	1600	1350	1320	1600	1350	1350	1600	1350	1320	1600	1350	1350	1600	1350	1320			
	2530	140	3930	4506	5	5	1600	1350	1350	1590	1350	1310	1600	1350	1350	1600	1350	1310	1600	1350	1350	1600	1350	1320			
	2780	140	4430	5006	5	5	1580	1330	1330	1530	1330	1290	1580	1330	1330	1580	1330	1300	1580	1330	1330	1580	1330	1300			
2 Stage FFL Hi-Vis	2080	1505	3215	3813	5	5	1600	1350	1350	1600	1350	1330	1600	1350	1350	1600	1350	1330	1600	1350	1350	1600	1350	1330			
	2330	1755	3715	4313	5	5	1600	1350	1350	1600	1350	1330	1600	1350	1350	1600	1350	1320	1600	1350	1350	1600	1350	1320			
	2680	2105	4335	4913	5	5	1600	1350	1350	1530	1350	1280	1600	1350	1350	1600	1350	1310	1600	1350	1350	1600	1350	1310			
3 Stage FFL Clear View	2080	1572	4600	5108	5	5	1500	1300	1300	1500	1300	1260	1500	1300	1300	1500	1300	1260	1500	1300	1300	1500	1300	1260			
	2180	1672	4900	5408	5	5	1490	1260	1260	1460	1260	1210	1500	1260	1260	1500	1260	1220	1500	1260	1260	1500	1260	1220			
	2330	1822	5200	5708	5	5	1380	1210	1210	1360	1210	1160	1410	1220	1220	1380	1220	1170	1400	1220	1220	1370	1220	1170			
	2430	1942	5500	6008	5	5	1240	1150	1150	1210	1150	1110	1270	1170	1170	1240	1170	1120	1250	1170	1170	1230	1170	1120			
3 Stage FFL Hi-Vis	2030	1455	4600	5175	5	5	1570	1320	1320	1500	1320	1270	1570	1320	1320	1570	1320	1290	1570	1320	1320	1570	1320	1290			
	2130	1555	4900	5375	5	5	1510	1280	1280	1460	1280	1240	1520	1280	1280	1520	1280	1240	1520	1280	1280	1520	1280	1240			
	2280	1705	5200	5775	5	5	1460	1230	1230	1430	1230	1190	1470	1240	1240	1470	1240	1200	1470	1240	1240	1470	1240	1200			
	2380	1805	5500	6075	5	5	1350	1170	1170	1310	1170	1130	1390	1190	1190	1350	1190	1150	1370	1190	1190	1340	1190	1150			

### ERP18 VT MWB/LWB mast details and capacity ratings (kg) - Supercushion tyres

Model					ERP 18 VT MWB							ERP 18 VT LWB												
Tyres					200 / 50-10							200 / 50-10												
Width across tyres					1116mm							1116mm												
Masts	OAH	FFH	MFH	h4	Tilt		Forks			Integral Sideshift				Forks			Integral Sideshift							
					F	B	Load Centre			Load Centre				Load Centre			Load Centre							
	h1	h2+s	h3+s				500	600	700	500	600	700	500	600	700	500	600	700	500	600	700	500	600	700
2 Stage LFL Hi-Vis	2180	140	3430	4006	5	5	1800	1600	1560	1800	1600	1470	1800	1600	1550	1800	1600	1470	1800	1600	1470	1800	1600	1470
	2530	140	3930	4506	5	5	1800	1600	1550	1800	1600	1470	1800	1600	1540	1800	1600	1470	1800	1600	1470	1800	1600	1470
	2780	140	4430	5006	5	5	1780	1580	1530	1780	1580	1450	1780	1580	1530	1780	1580	1450	1780	1580	1450	1780	1580	1450
	3130	140	4930	5506	5	5	1580	1500	1440	1540	1500	1360	1580	1500	1440	1540	1500	1370	1580	1500	1370	1580	1500	1370
2 Stage FFL Hi-Vis	2080	1505	3215	3813	5	5	1800	1600	1560	1800	1600	1480	1800	1600	1560	1800	1600	1480	1800	1600	1480	1800	1600	1480
	2330	1755	3715	4313	5	5	1800	1600	1560	1800	1600	1470	1800	1600	1560	1800	1600	1470	1800	1600	1470	1800	1600	1470
	2680	2105	4335	4913	5	5	1800	1600	1550	1770	1600	1470	1800	1600	1550	1800	1600	1470	1800	1600	1470	1800	1600	1470
3 Stage FFL Hi-Vis	2030	1455	4600	5175	5	5	1770	1570	1530	1750	1570	1440	1770	1570	1520	1770	1570	1440	1770	1570	1440	1770	1570	1440
	2130	1555	4900	5475	5	5	1710	1520	1470	1700	1520	1390	1710	1520	1470	1710	1520	1390	1710	1520	1390	1710	1520	1390
	2280	1705	5200	5775	5	5	1650	1470	1420	1650	1470	1340	1650	1470	1410	1650	1470	1340	1650	1470	1340	1650	1470	1340
	2380	1805	5500	6075	5	5	1590	1410	1360	1580	1410	1280	1590	1410	1350	1580	1410	1280	1590	1410	1350	1580	1410	1280

### ERP20 VT MWB/LWB mast details and capacity ratings (kg) - Supercushion tyres

Model					ERP 20 VT MWB							ERP 20 VT LWB												
Tyres					200 / 50-10							200 / 50-10												
Width across tyres					1116mm							1116mm												
Masts	OAH	FFH	MFH	h4	Tilt		Forks			Integral Sideshift				Forks			Integral Sideshift							
					F	B	Load Centre			Load Centre				Load Centre			Load Centre							
	h1	h2+s	h3+s				500	600	700	500	600	700	500	600	700	500	600	700	500	600	700	500	600	700
2 Stage LFL Hi-Vis	2180	140	3430	4006	5	5	2000	1800	1700	1990	1780	1620	2000	1800	1700	1990	1780	1620	2000	1800	1700	1990	1780	1620
	2530	140	3930	4506	5	5	2000	1800	1690	1980	1780	1610	2000	1800	1690	1980	1780	1610	2000	1800	1690	1980	1780	1610
	2780	140	4430	5006	5	5	1980	1780	1680	1940	1760	1590	1980	1780	1680	1910	1760	1590	1980	1780	1680	1910	1760	1590
	3130	140	4930	5506	5	5	1570	1570	1570	1520	1520	1510	1570	1570	1570	1520	1520	1500	1570	1570	1570	1520	1520	1500
2 Stage FFL Hi-Vis	2080	1505	3215	3813	5	5	2000	1800	1710	2000	1790	1620	2000	1800	1710	2000	1790	1620	2000	1800	1710	2000	1790	1620
	2330	1755	3715	4313	5	5	2000	1800	1700	1990	1790	1620	2000	1800	1700	1990	1790	1620	2000	1800	1700	1990	1790	1620
	2680	2105	4335	4913	5	5	2000	1800	1690	1940	1780	1610	2000	1800	1680	1910	1750	1610	2000	1800	1680	1910	1750	1610
3 Stage FFL Hi-Vis	2030	1455	4600	5175	5	5	1970	1770	1670	1910	1750	1580	1960	1770	1670	1880	1730	1580	1960	1770	1670	1880	1730	1580
	2130	1555	4900	5475	5	5	1910	1720	1620	1870	1690	1540	1900	1710	1610	1840	1690	1530	1900	1710	1610	1840	1690	1530
	2280	1705	5200	5775	5	5	1850	1660	1560	1820	1640	1480	1810	1650	1550	1760	1620	1470	1810	1650	1550	1760	1620	1470
	2380	1805	5500	6075	5	5	1720	1600	1500	1690	1580	1430	1650	1590	1490	1620	1560	1410	1650	1590	1490	1620	1560	1410

Note that the capacities are given in kilograms. All ratings with DIN Battery. All ratings with 1000mm forks and less load backrest.

## VT Series

Models: 15VT SWB, 16VT SWB/MWB/LWB, 18VT MWB/LWB, 20VT MWB/LWB

### AC Technology

Yale AC technology Class H traction motors are suitable for the most arduous applications. Smooth forward and reverse directional changes providing seamless driving action. In the high-performance or 'HiP' setting, AC technology provides increased speed and acceleration, even when fully laden, and increased speed on grade. As well as improving performance, AC technology reduces maintenance and allows service intervals of 1000 hours for most components.

### Brakes

The truck is equipped with automatic park brake and oil immersed brakes. Automatic YaleStop™ park brake: spring applied, electro magnetically released park brakes are mounted at the end of both motors. The park brake is automatically set by the control system, so that the brake is always set whenever the truck is not moving, and no traction has been requested. Moreover the park brake provides controllability on ramp applications.

### Steering

A 12 KW AC motor drives a pump which provides oil pressure for the hydraulic pump and for steering, eliminating the need for a separate steering motor and pump. The steering column is infinitely adjustable in a range of 26°. During cornering the speed of the drive motors is continuously adjusted independently by the traction controller ensuring smooth operation. Twin steer tyres provide long tyre life, low power consumption and increased stability.

### 'eLo' and 'HiP' Settings

Yale VT trucks feature an 'eLo' energy saving setting (accessible via the overhead display with service password), which provides exceptional energy efficient performance for when you require continuous operation over longer periods without recharging the battery. You can choose the 'HiP' high performance setting for higher top speeds and acceleration for the most demanding applications.

### Performance modes

Performance of the truck can be tailored via the enhanced overhead

display, with 4 performance modes available to suit the requirements of the application or the preferences of the driver. For maximum speed and acceleration, choose mode 4, or for more delicate maneuvering and extended battery life, mode 1 is ideal. Your service technician can alter the top speed and acceleration of mode 4, with modes 1, 2 and 3 being automatically adjusted as percentages of setting 4.

### Improved ergonomics

The VT is designed for optimum operator comfort.

The operator is seated in an ergonomically designed position for maximum safety, comfort, visibility and ease of operation. The truck features a very low step height, generous floor and storage space, standard grab handle for ease of entry and standard reverse grab handle. The seat is a Sears FLM 80 with 80mm of suspension and a swivel seat option for a superior reverse driving position. Both the mini-lever module and the manual levers have an integrated direction switch. Clear footwell allows easy access from both sides.

### Masts

A full range of Yale Hi-Vis™ 2 stage LFL and 2 and 3 stage FFL masts are available. Yale Hi-Vis™ masts are designed for maximum visibility, with widely spaced channels, lift chains and main lift cylinders. The new Yale Clear View™ Mast with class-leading visibility is offered on the 1.5T and 1.6T capacities.

### Battery

Choice of 2 battery sizes: DIN and BS.

Choice of 3 wheelbases: Depending on the capacity, there is a choice of Short Wheelbase (SWB), Medium Wheelbase (MWB), and Long Wheelbase (LWB). The LWB versions provide extra battery space and longer shift life. SWB versions offer improved maneuverability and reduced stacking aisle dimensions. Battery discharge indicator and lift interrupt are standard on all trucks.

### Low lifetime costs

Lower maintenance costs as a result of less maintenance by oil immersed brakes, electric park brake, and

CANbus and AC technology. Transmission is sealed for life, eliminating the need for service. LED light packages are offered as an option. 1000 hours service interval for most components.

Auto Regen Braking optimises the shift life of the battery and contributes to an increase in the life of parts.

### Options

- Accutouch mini-levers
- Foot directional control
- Lighting kits, including LED lights
- Reverse alarm
- Integrated sideshift
- DIN and BS battery
- Side battery extraction



NACCO Materials Handling Limited trading as Yale Europe Materials Handling  
Flagship House, Reading Road North, Fleet, Hampshire GU51 4WD, United Kingdom.  
Tel: + 44 (0) 1252 770700 Fax: + 44 (0) 1252 770784  
[www.yale-europe.com](http://www.yale-europe.com)

Country of Registration: England. Company Registration Number: 02636775



**Safety.** This truck conforms to the current EU requirements. Specification is subject to change without notice.

Publication part no. 258725897 Rev.04

Printed in The United Kingdom (0909HG) EN

Yale is a registered trade mark.  
© Yale Europe Materials Handling 2009. All rights reserved.  
Truck shown with optional equipment